

F2236

DOD 32236

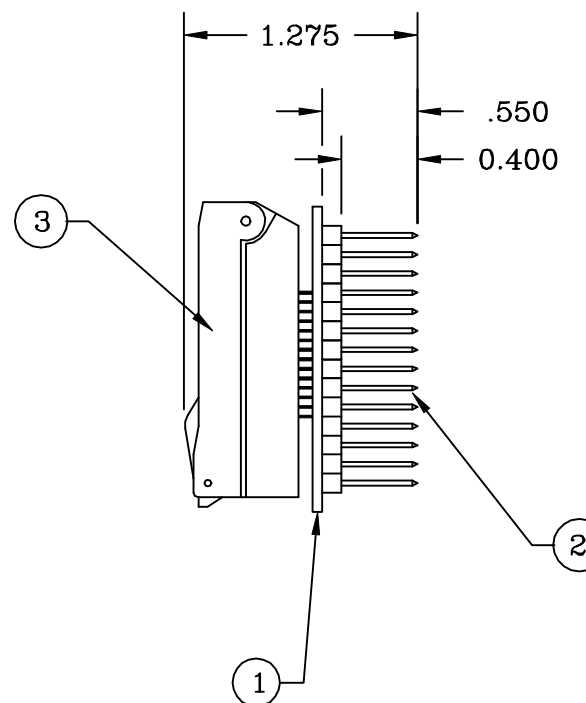

ALL DIMENSIONS ARE IN INCHES UNLESS OTHERWISE SPECIFIED

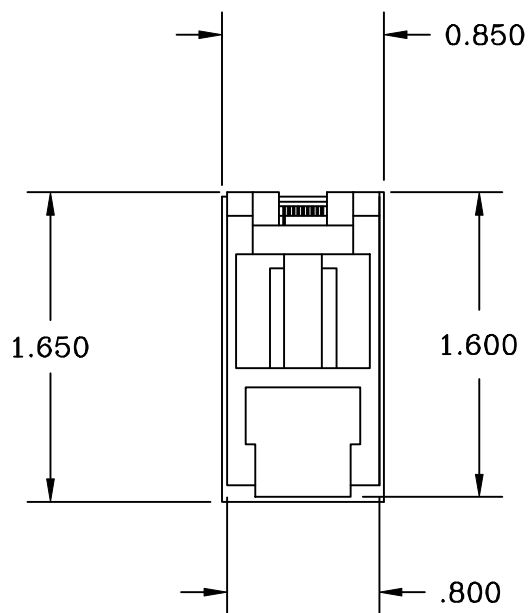

Emulation Technology, Inc.

— VLSI and SMT ADAPTERS and ACCESSORIES —

2344 Walsh Avenue, Bldg. F
Santa Clara, Ca 95051

TEL:(408)982-0660
FAX:(408)982-0664

NO.	ITEM	DESCRIPTION	QTY.
1	AG-28-28-01/03S	TOP BOARD	1
2	WWPOST-40-PGA	DIP TEST PINS ON BOTTOM	1
3	S-SOR-00-028-A	REGULAR SO TOP SOCKET	1

SHEET: 1 OF 1	DATE: 1/17/00	REVISION:	ASSEMBLY DRAWING
CHECKED: PAULA OLSON	DRAWN: JAMES GOUVEIA	ITEM: 282803S600-GANG	
DO NOT SCALE DRAWING			DESCRIPTION: AS-28-28-03S-6-GANG