

RECOMMENDED FOOTPRINT
SCALE 2:1

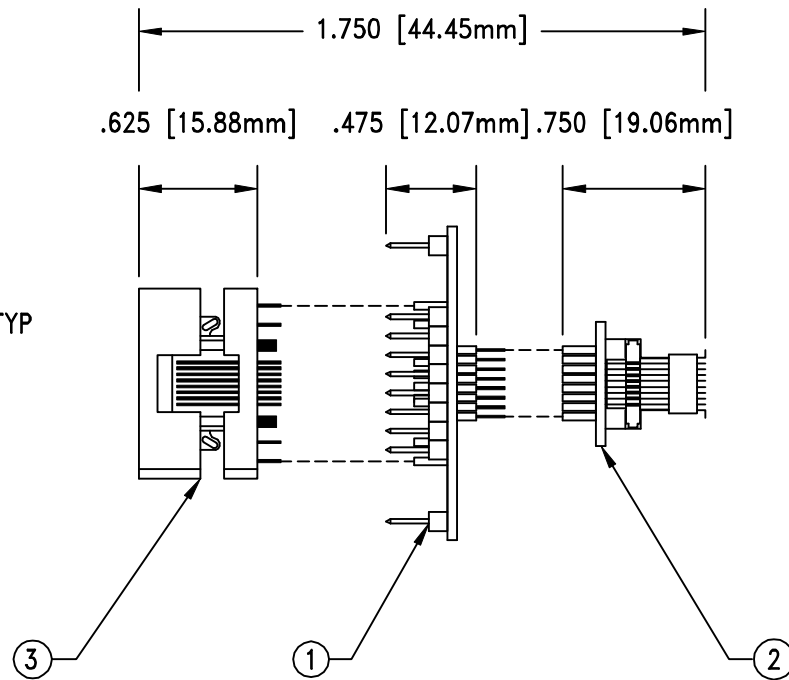

PACKAGE CODE: 32-QF59D
PACKAGE DIMENSIONS:
LEAD PITCH= 0.80mm
BODY SIZE= 7.0mm
TIP TO TIP= 9.0mm

ALL DIMENSIONS ARE IN INCHES UNLESS OTHERWISE SPECIFIED

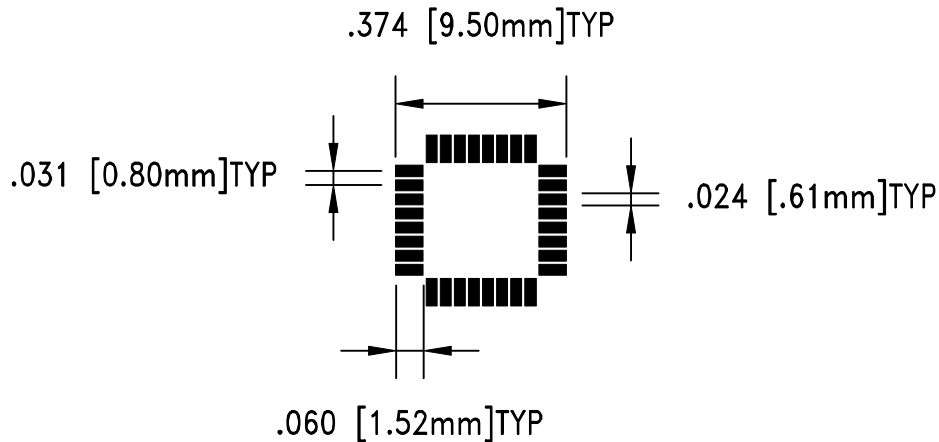

Emulation Technology, Inc.
— VLSI and SMT ADAPTERS and ACCESSORIES —

2344 Walsh Avenue, Bldg. F
Santa Clara, Ca 95051

TEL:(408)982-0660
FAX:(408)982-0664

NO.	ITEM	DESCRIPTION	QTY.
1	AX-32-QF59DZ	TOP SUB ASSEMBLY	1
2	EPP032QF59DSM	BOTTOM SUB ASSEMBLY	1
3	S-QFP-00-032-A	PLUG IN ON TOP OF #1	1

SHEET: 1 OF 1	DATE: 8/30/00	REVISION:	ASSEMBLY DRAWING
CHECKED: PAULA OLSON	DRAWN: AARON FINE	ITEM: BC-V-590DZ/1	
DO NOT SCALE DRAWING			DESCRIPTION: BCP-032-QF59DZ-0000-1