



Giga Test Labs

**POST OFFICE BOX 1927 CUPERTINO, CA
TELEPHONE (408) 524-2700 FAX (408) 524-2777**

Emulation Technology, Inc.

ET 1.27 MM PITCH BGA SOCKET

Final Report

March 1, 2001

**Electrical Characterization
0.05 - 3.05 GHz**

Table of Contents

| Subject | page |
|---|-------------|
| Table of Contents..... | 2 |
| Summary..... | 3 |
| Objective..... | 3 |
| Methodology..... | 3 |
| Measurement system..... | 3 |
| Equivalent-circuit model..... | 3 |
| Figure 1 - BGA socket equivalent-circuit diagram..... | 4 |
| Element definitions..... | 4 |
| Element values..... | 4 |
| Table 1 - Element values for ET BGA socket..... | 5 |
| Conclusions..... | 5 |
| Figure 2 - Bandwidth measurement..... | 5 |
| Appendix..... | 6 |

Summary

Objective

The ET BGA socket (1.27 mm pitch) was measured at GigaTest Labs to assess its electrical performance. SPICE-compatible lumped element models were derived from the measured data. Also, its high-speed performance limits were determined.

Methodology

The ET sockets were mounted onto custom PCBs fabricated by ET with GTL guidance. These PCBs were designed to exhibit low parasitics and allow the use of coplanar probes. A second set of PCBs with measurement standard patterns was mounted on the device side of each socket. This would allow pins to be measured under three conditions (open, shorted and thru). The Agilent ADS (Advanced Design System) software version 1.3 was then used to extract equivalent-circuit models which are SPICE compatible.

Measurement system

All measurements were taken using a high-frequency measurement system. This consists of a Hewlett-Packard 8510C network analyzer & GGB Picoprobes™ 450 μm pitch. The HP 8510C network analyzer is a frequency domain instrument. The measurements are taken as scattering parameters (a.k.a. s-parameters). The HP8510C has great calibration capabilities, which make it the most accurate high-frequency instrument available. For this work the short-open-load-thru (SOLT) calibration was used. The GGB Picoprobes provide a high-quality 50 Ω path from the network analyzer and cables to the DUT.

Equivalent-circuit model

Figure 1 shows the topology used to model the BGA socket and the solder-ball connections between the PCB and the surrogate package.

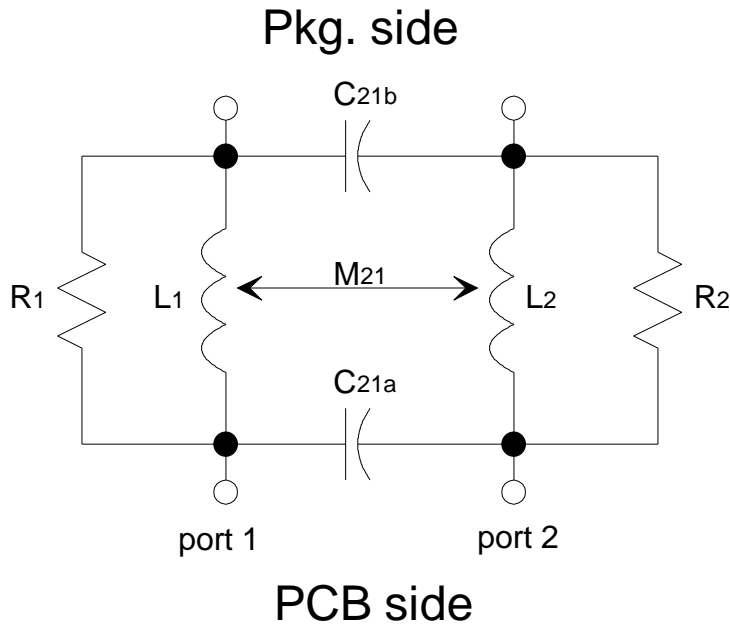

Figure 1 - BGA socket equivalent-circuit diagram

Element definitions

- L₁, L₂:** pin self-inductance
- M₂₁:** mutual-inductance between adjacent pins
- R₁, R₂:** shunt-resistance of inductors L₁ and L₂, used to model high-frequency loss due to skin effect and dielectric loss
- C_{21a}:** mutual-capacitance between adjacent pins (PCB side)
- C_{21b}:** mutual-capacitance between adjacent pins (BGA side)

Element values

The models are valid from DC to 3.05 GHz. The measured and modeled transmission response agrees within 0.1 dB. A model was extracted for four types of pins: adjacent field pins, field pins oriented diagonally, edge pins and corner pins.

Table 1 - Element values for ET BGA socket

| pins | L₁ & L₂ (nH) | M₂₁ (nH) | R₁ & R₂ (W) | C_{21a} (pF) | C_{21b} (pF) |
|-----------------|---|--------------------------------|--|---------------------------------|---------------------------------|
| field adjacent | 1.25 | 0.120 | 800 | 0.020 | 0.030 |
| field diagonal | 1.25 | 0.025 | 800 | 0.008 | 0.010 |
| edge adjacent | 1.31 | 0.160 | 700 | 0.025 | 0.040 |
| corner adjacent | 1.50 | 0.180 | 700 | 0.030 | 0.040 |

Conclusions

1. The bandwidth for the BGA socket was determined from a loop-thru measurement on two adjacent pins. The nearest row of pins was grounded (see figure 2). The 1 dB bandwidth was measured at 9.3 GHz (please see page 10 in the appendix).

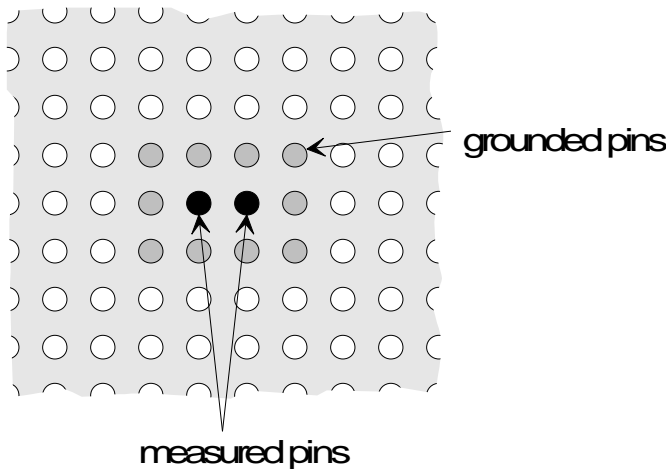

Figure 2 - Bandwidth measurement

2. The model bandwidth is DC-3.05 GHz, which will handle signals with 125 ps edges.
3. Capacitance to ground of up to 0.2 pF was detected on all the pins. To account for this, two capacitors to ground can be added on either side of L1 and L2. Their values should be 0.1 pF each.

Appendix

The appendix shows the measured (blue traces) and simulated (red traces) results.

| Measured and simulated data | page |
|---|-------------|
| ET BGA socket..... | 7 |
| Open measurement | 7 |
| Short measurement | 8 |
| Thru measurement..... | 9 |
| Loop-thru bandwidth measurement (10 GHz)..... | 10 |

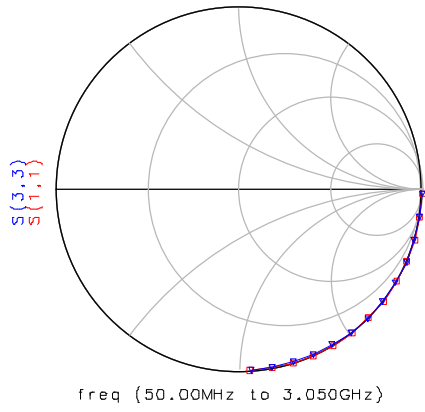

Adjacent Open Response

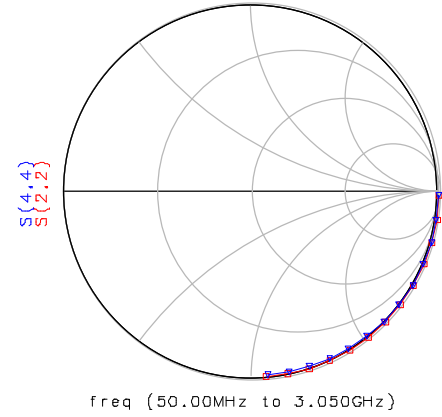
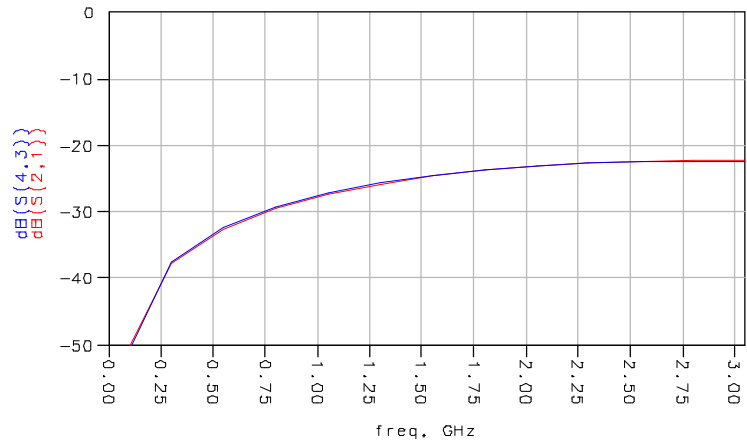

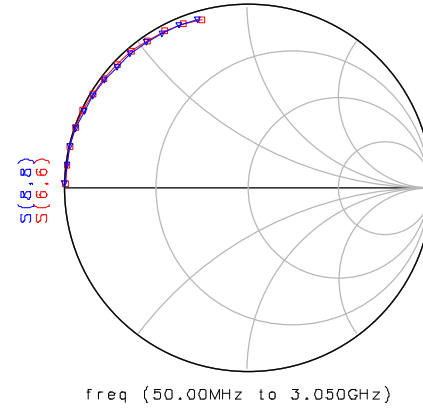
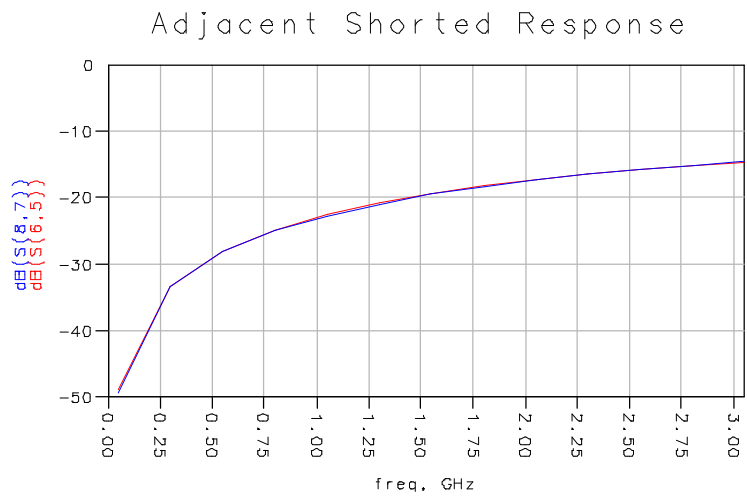
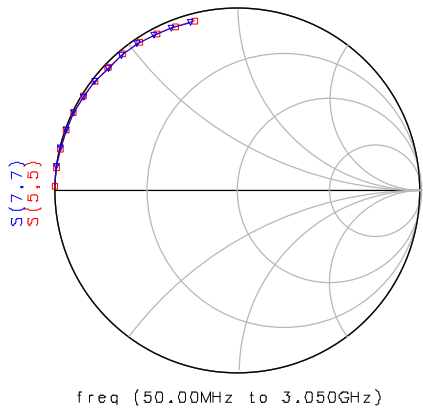

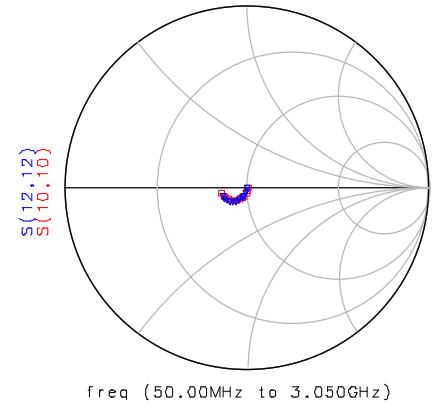
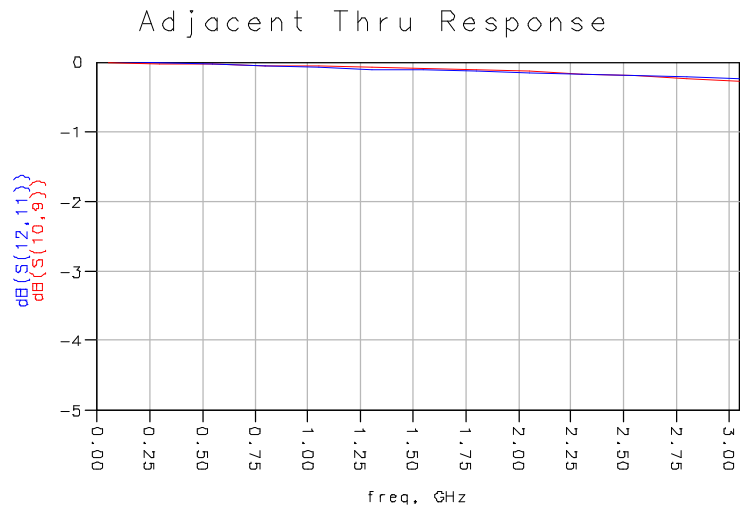
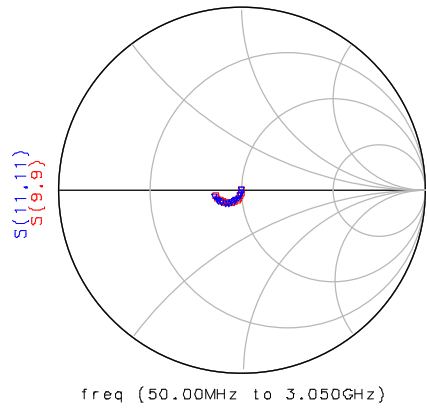

Loop-Thru bandwidth measurement

